

STRAFLEX® WITH SEPARATE HUB

* Torsional flexibility * Radial flexibility ** Axial flexibility ** Conical flexibility

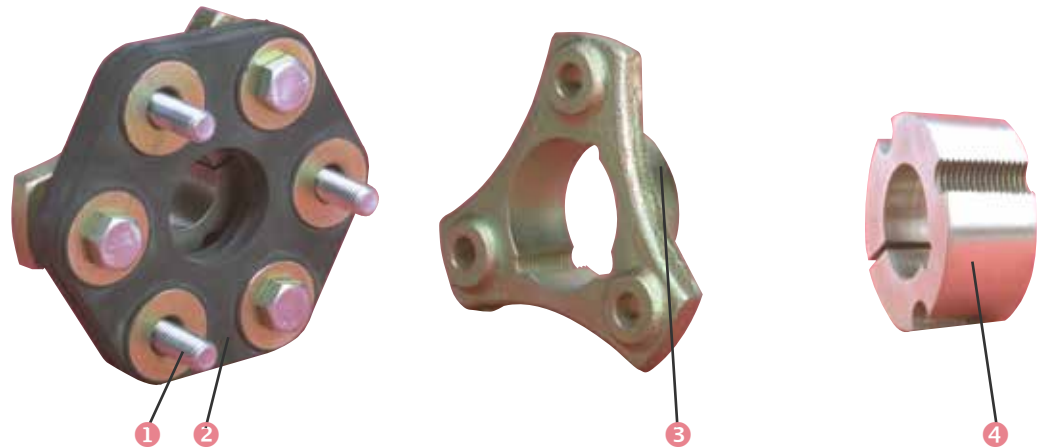

DESCRIPTION

- Flexible element
 - ① Metallic bobbins linked together by rayon fibres.
 - ② The whole unit ① is potted in natural rubber and is hexagonal.
- Flange
 - ③ Forged steel specially bored to accommodate the separate hub.
 - ④ Universal separate hub (not supplied by PAULSTRA).

OPERATION

In addition to the characteristics described above, the separate hub used in conjunction with the STRAFLEX coupling provides the advantage: ready to assemble without machining.

Advantages

- Reduced size.
- Simplified axial positioning.
- Easy to assemble and disassemble.
- Reduction of costs by simplifying the machining required for the shafts and flanges.

Recommendation

- The reinforced textile structure means that it has a low tolerance to irregularities in the torque.

DIMENSIONS

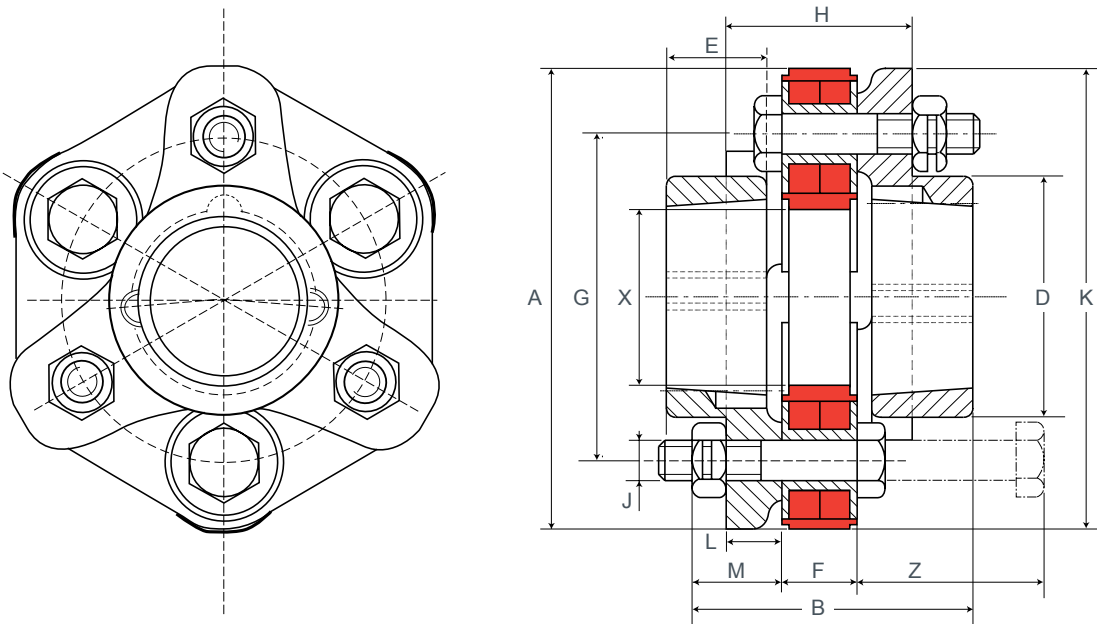

Ref.	Nominal torque (N.m)	Max torque (N.m)	Max speed (rpm)	Separate hub*	A (mm)	B (mm)	D (mm)	E (mm)	F (mm)	G (mm)	H (mm)	J (mm)	K (mm)	L (mm)	M (mm)	X (mm)	Z (mm)	Weight (kg)
635305	100	200	5 500	SEE PARTS LIST	94	61	48	20	15	65	41	8	91	11	23	28	45	0,9
635306	200	400	5 000		120	76	60	25	18	85	51	12	121	14	29	40	60	1,6
635307	400	800	4 500		140	81	70	25	21	100	56	14	140	17	30	44	70	2,7
635308	800	1 600	3 500		178	96	95	30	26	132	66	16	177	21	35	66	80	5

1 N.m ≈ 0,1 mkg

* For shaft diameters, please refer to the hub manufacturers' specifications.

The maximum torque is considered to be an infrequent start-up torque and not periodic.

PARTS LIST

Coupling Reference	Flexible element		Flange		SEPARATE HUB	
	Reference	Qty	Reference	Qty	Current Reference	Universal Reference
635305	635632	1	321316	2	28 - 20	11 - 08
635306	635633	1	321815	2	30 - 25	12 - 10
635307	635634	1	321819	2	40 - 25	16 - 10
635308	635635	1	321827	2	50 - 30	20 - 12

OPERATING LIMITS

POWER RANGE

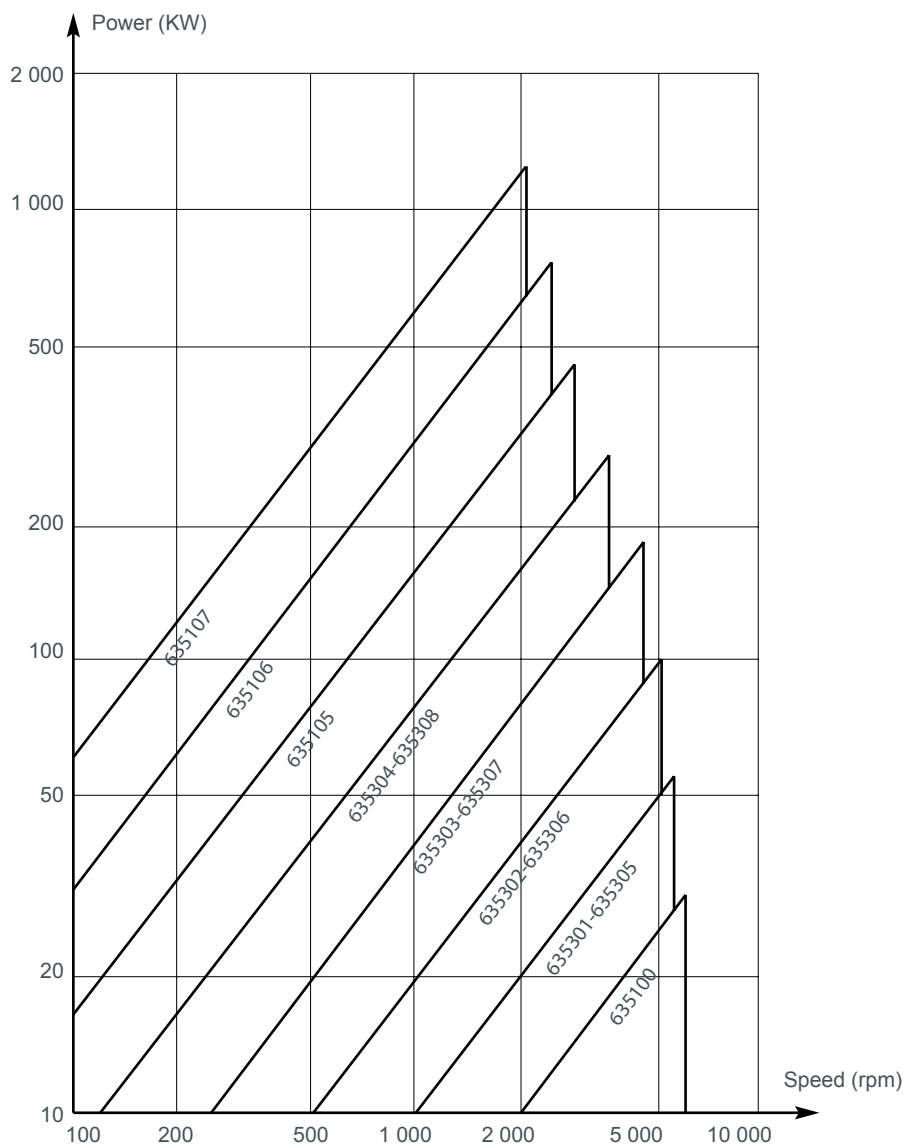

OPERATING CHARACTERISTICS

Nominal torque (N.m)	Vibrat. coupling (N.m)	Torsion under NT (degrees)	Stiffness			
			Axial (Dan/Mm)	Radial (Dan/Mm)	Torsional (M.kn/Rad.)	Conical (M.kn/Rad.)
50	25	6	30	150	0,46	0,08
100	50	3	20	70	1,9	0,114
200	100	1°45	25	180	6,6	0,2
400	200	2°30	60	150	9,2	0,29
800	400	1°45	30	150	26	0,57
1 600	800	2°20	50	150	40	1,43
3 200	1 600	2	120	180	73	2,3
6 000	3 000	2	75	200	172	3,44

1 N.m ≈ 0,1 mkg

ASSEMBLY

Method :

- mount the flanges on the shafts of the machines to be coupled;
- position the flexible element to attach three non-adjacent bobbins to one flange with bolts, then attach the three other bobbins to the second flange.

NOTE : For the 635100 coupling, the bolts are replaced by welded studs and so this must be assembled by pushing the flanges together.

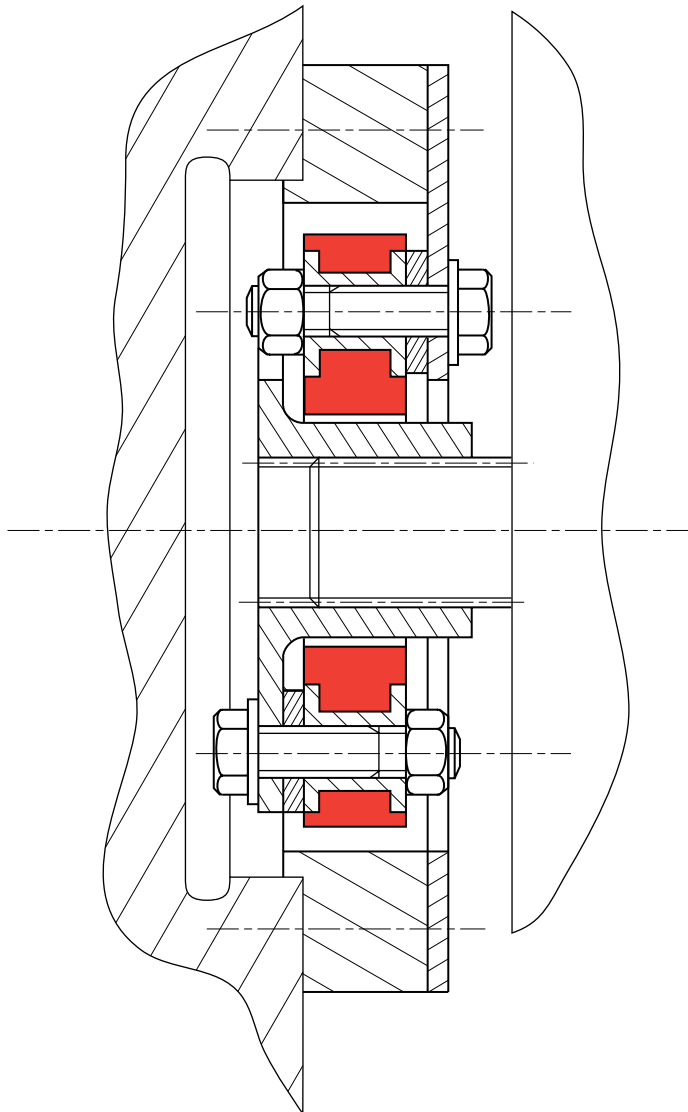

Example : electric motor/volumetric pump coupling : mounted on channelled shaft and flywheel.